

3D Printing and MEMS Propulsion for the RAMPART 2U CUBESAT

Gilbert Moore
Project Starshine
3855 Sierra Vista Road, Monument, CO 80132; 719-488-0721; gilmoore12@aol.com

Walter Holemans
Planetary Systems Corporation
2303 Kansas Ave., Silver Spring, MD; 301-495-0737; walt@planetarysystemscorp.com

Adam Huang, John Lee and Matthew McMullen
Department of Mechanical Engineering, The University of Arkansas
105 Engineering Building, Fayetteville, AR 72701; 479-575-4054; phuang@uark.edu

Jim White
Colorado Satellite Services
45777 Rampart Road, Parker, CO 80138-4316; 303-840-1907; jim@coloradosatellite.com

Robert Twiggs, Benjamin Malphrus and Nathan Fite
Space Science Center, Morehead State University
200A Chandler Place, Morehead, KY 40531; 606-783-9594; rtwiggs@moreheadstate.edu

David Klumpar, Ehson Mosleh and Keith Mashburn,
Space Science and Engineering Laboratory, Montana State University
P.O. Box 173840, Bozeman, MT 59717-3840; 406-994-6169; klump@physics.montana.edu

David Wilt and James Lyke
U.S. Air Force Research Laboratory/Space Vehicles Directorate
Building 472, Kirtland AFB, NM, 87117-5776;
505-846-2462, david.wilt@kirtland.af.mil ; 505-846-5812; james.lyke@kirtland.af.mil

Stewart Davis
CRP USA, LLC
119 Poplar Pointe Drive, Unit A, Mooresville, NC 28117; 562-458-4036; sdavis@crptechnology.com

Wes Bradley
Analytical Graphics, Inc.
220 Valley Creek Blvd. Exton, PA 19341; 610-981-8000; Wes@agi.com

2Lt. Thomas Chiasson, USAF
Class of 2010 Astronautics Graduate of the United States Air Force Academy. CO;
At MIT Fall 2010; 719-439-1286; tmchiasson@gmail.com

Jay Heberle
Universal Space Network
2009 Indian Circle, St. Leonard, MD 20685, 410-586-9508; jheberle@uspacenet.com

Pat Patterson
Space Dynamics Laboratory
1695 North Research Park Way, North Logan, UT 84321, 797-4112, pat.patterson@sdl.usu.edu

ABSTRACT

A volunteer consortium of the individuals and organizations listed on the title page of this document is using rapid prototyping and MEMS technologies to design and build a 2U RAMPART CUBESAT (RApidprototypedMemsPropulsionAndRadiationTest CUBEflowSATellite) that is in the process of being manifested on a Falcon 1e launch. The flight of this satellite is intended to certify warm gas propulsion subsystems and magnetic stabilization for Cubesat orbital altitude adjustment, as well as rapid prototyping methods of building one-piece satellite structures, propellant tanks, printed circuit board cages, erectable solar panels, antenna deployment mechanisms, etc. at a fraction of the cost of current methods. Design revisions are being accommodated with a minimum of effort, time and expense. New laser-sintered materials with improved mechanical and thermal properties are being adapted for space

use from the Formula 1 Racing field. Polymer sealants and metal platings have been utilized on surfaces inside and outside the satellite to eliminate outgassing and to aid in thermal management. This paper describes the use of these techniques to design-print-fly a 2U Cubesat that will raise its own apogee altitude to 1200 km, just below the equatorial inner Van Allen Radiation Belt, following deployment from its launch vehicle into an initial 450km circular orbit with an inclination of 45 deg. The satellite will measure incident energetic particle flux, together with the performance of new, improved radiation-hardened Cubeflow components and circuits and high-performance solar cells and cover glasses in that enhanced radiation environment, and telemeter those measurements to a redundant international ground station network.

BACKGROUND

Cubesat experimenters are frequently forced to accept piggyback flight opportunities on launch vehicles that may place them in orbits that are not necessarily ideal for their scientific objectives. In order to help solve that problem, a team of volunteers is developing a non-hazardous warm gas (resistojet) propulsion system that is housed within a 1U Cubesat structure and is designed to be attached to 1U or 2U Cubesats and employed, together with magnetic stabilization, to adjust their orbital altitudes to values more suited to their needs.

To demonstrate this concept, our team members are utilizing a combination of rapid prototyping and microelectromechanicalsystem (MEMS) technologies to design and manufacture this resistojet propulsion system and attach it to a 1U Cubesat bus, which they have also created by the rapid prototyping process, to form a 2U Cubesat called RAMPART.

The use of this design method dramatically reduces turnaround time and cost of design iterations that are typically encountered in satellites designed by team members located apart from each other. An examination of the list of authors of this paper, who are the team members building the RAMPART satellite, will illustrate the usefulness of this design

and manufacturing method. The members of our team have never all been together in the same room at the same time. We have conducted our meetings and design reviews in Webcasts, in which Walter Holemans of Planetary Systems Corporation,, our principal mechanical designer, displays a PDF containing a maneuverable Solid Works structural model on everyone's screen, inserts the images of circuit boards, antennas, connectors, solar arrays, etc. that are provided by the other team members, and alters the design in real time, in response to comments and requests from the others. He then emails his design to a rapid prototyping facility that 3D prints it and overnights it back to him. He then makes a fit check of the physical components and sends everything to Jim White of Colorado Satellite Services, our system engineer/integrator, who connects the electronic components and runs end-to-end system functional tests in preparation for vibration, thermal/vacuum and radiation testing.

Rapid prototyping has been employed to prepare test models of many kinds; however, to date, the physical properties of printed materials have been inadequate for use in spacecraft. To the authors' knowledge, RAMPART will be the first satellite manufactured by the rapid prototyping process and flown in space.

Walter Holemans has collaborated with Stewart Davis of CRP USA, LLC and Frank Huizar of Quaker City Plating to adapt this process for space use through laser sintering and Nickel plating of WINDFORM materials, which are currently used extensively in the manufacture of Formula One

racing cars and wind tunnel models. Structures made from these materials have superior strength, brittleness and thermal properties over other printed materials, and we have recently subjected them to standard ASME testing and found them to be acceptable for space use.

SATELLITE DESCRIPTION

In its stowed configuration, the RAMPART satellite is a 2U (10cm x 10cm x 20cm) Cubesat that can share space with a separate 1U Cubesat in a standard

3U Poly Picosat Orbital Deployer (PPOD). Its total weight, including 0.6kg of propellant, is 2 kg.

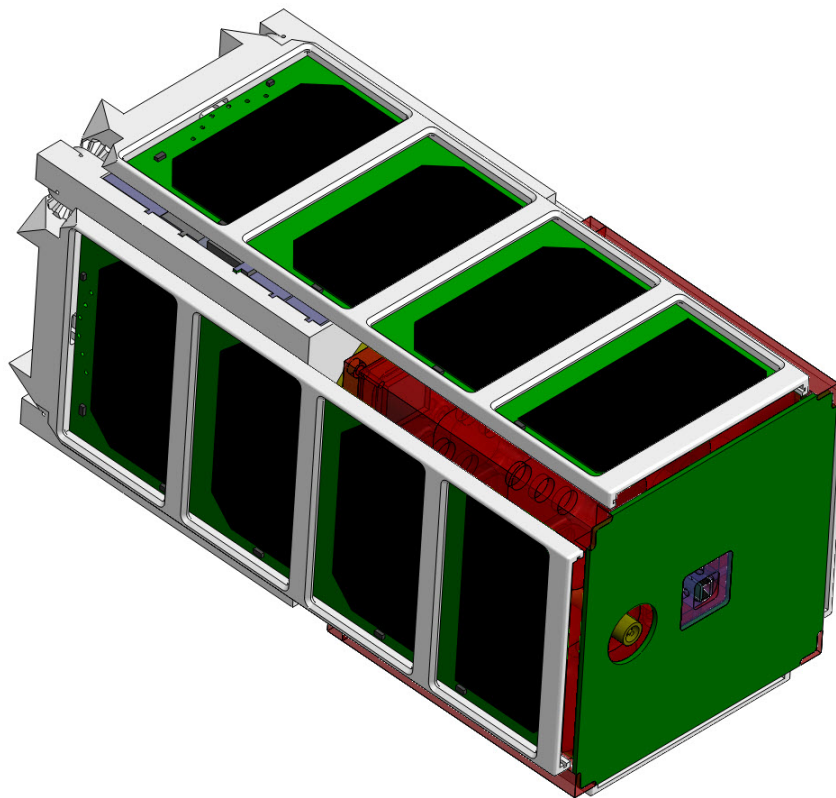

Figure 1. Stowed view of RAMPART Cubesat

The satellite's bus structure is a 3D-printed and Nickel-plated card cage into which are inserted a battery card, four printed circuit boards and a multiple-antenna deployment system. The 3D-printed battery card contains eight Sanyo HR-4/3AAUP Nickel Metal Hydride (NMH) batteries.

The first printed circuit board contains a data handling and electrical power control system

(DH/EPS) provided by Jim White of Colorado Satellite Services. He presented this design in a paper entitled "CSS Bus for Rampart" at the 2010 Spring Cubesat Developers Workshop at Cal Poly San Luis Obispo in May, 2010¹. The paper can be viewed on the Cubesat.org web site

This board also contains a 34mm x 68mm x 12.5mm experiment provided by Dr. James Lyke of the U.S.

Air Force Research Laboratory Space Vehicles Directorate (AFRL/RV) to gather radiation performance statistics on three different types of plug-and-play modules – a radiation hardened SPA-1 Applique Sensor Interface Module (ASIM) made in the U.S., a rad-hard SPA-1 ASIM made in Sweden and a commercial U.S. PIC.

The second board contains an energetic particle measurement experiment, named DAVE, provided by Dr. David Klumpar and his graduate students at Montana State University. Mounted on this board is a Geiger-Mueller tube identical to those flown by Dr. James A. Van Allen in 1958 in Explorers 1 and 3 to discover a belt of trapped energetic particles around the earth. The board also contains a 12.5mm diameter, 10cm long Neodymium permanent magnet with a field strength of 703 Gauss at a distance of 10cm that will continually align RAMPART's longitudinal axis with the earth's magnetic field.

The third board contains an AstroDev Be-1 2.4 GHz BPSK telemetry transmitter. The fourth board contains an AstroDev He-100 FSK/GMSK 437MHz/145.8MHz telemetry transceiver.

The somewhat soft electronic devices in this satellite have been protected by tantalum wafers to extend their lifetimes to the greatest possible extent in the enhanced radiation environment to which they will be subjected during apogee passes.

Two sets of measuring-tape quarter-wave dipole UHF and VHF antennas and one monopole S-band antenna are also coiled up inside the bus. The telemetry boards and antennas are being provided by Professor Bob Twiggs and Nathan Fite of Morehead State University.

Attached to the front end of the satellite bus structure are four geared, double-sided, erectable 3D-printed solar panels on which are mounted a total of 32 SpectroLab triple-junction 26% efficient solar cells, covered by a combination of conventional and experimental cover glasses. The solar cells and cover glasses are being provided by David Wilt of AFRL/RV and mounted to the panels by Nathan Fite with guidance from AFRL. These panels are erected by an electric motor which has been previously flown in space on many occasions to actuate Planetary Systems Lightband deployment systems.

Bonded to an external face of the bus is another experiment provided by David Wilt to evaluate the long-term performance of advanced photovoltaic technologies, including a 4-junction 33% efficient Inverted Metamorphic Multijunction (IMM) solar cell, in a high-radiation environment. A 2cm x 2cm IMM cell is mounted next to a conventional 2cm x 2cm triple junction cell on a common circuit card for comparison purposes.

Attached to the back of the satellite bus structure is a warm gas (resistojet) propulsion system that will be described in a later section of this paper. Here is a cutaway view of the satellite in its stowed configuration.

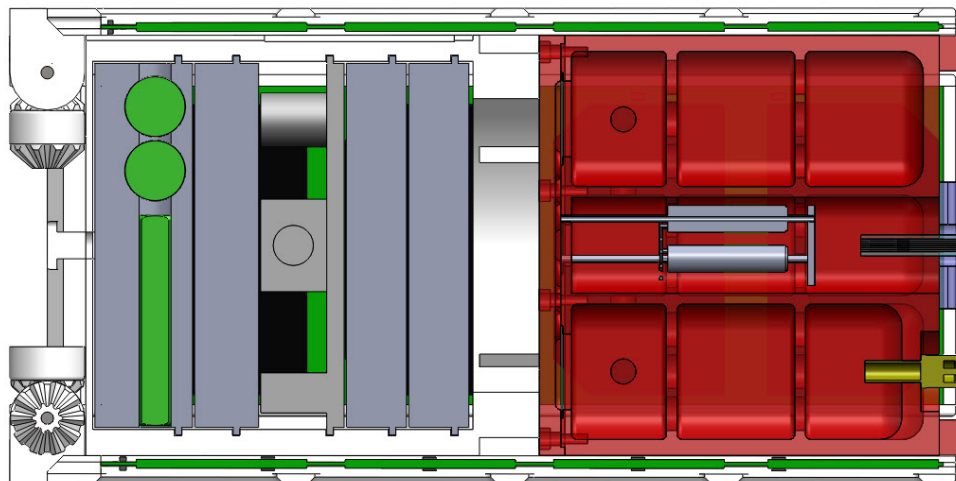

Figure 2. Cutaway View of Bus. Folded Solar Panels and Attached Propulsion Module

RAMPART's batteries can be discharged before it is inserted into its PPOD, if desired by the vehicle integrator, in order to eliminate Electromagnetic Interference (EMI) concerns. After RAMPART has been launched into orbit and deployed from its carrier vehicle, its depleted batteries will begin to charge, and its CPU will command an electric motor to erect

four double-sided solar arrays, that are hinged from the front end of the spacecraft bus, and sweep them forward to an angle of 135 deg from the satellite's longitudinal axis. The CPU will then command the heating of a Nichrome wire that will melt a Nylon line and allow the telemetry system's coiled antennas to unwind.

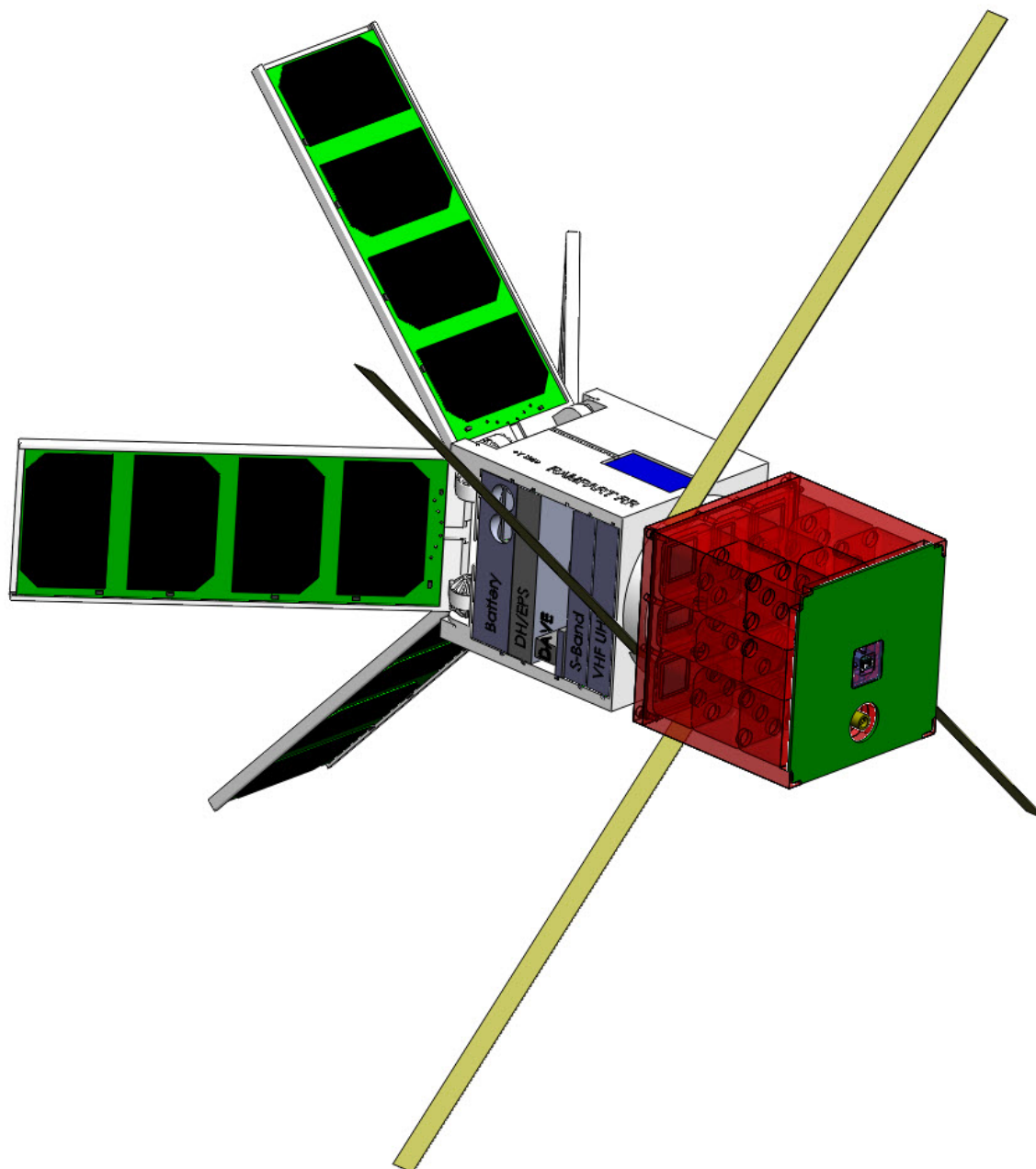

Figure 3. Deployed RAMPART 2U Cubesat with covers removed for clarity

RAMPART PROPULSION SYSTEM (RPS) DESCRIPTION

A warm gas propulsion system has been developed for RAMPART by Dr. Adam Huang and his graduate students in the University of Arkansas Department of Mechanical Engineering, using rapid prototyping and MEMS technologies. The RPS is contained in a 1U Cubesat that is attached to a 1U Bus that contains the remaining components of the satellite. It is based on a warm-gas (resistojet) configuration that raises the baseline vacuum specific impulse, I_{sp} , of its propellant from 67s to 90s by adding heat energy to the propellant prior to its conversion to kinetic energy at the nozzle. The propellant of choice for the RPS is the pharmaceutical grade of DuPont™ Dymel®-134a ([1,1,1,2-Tetrafluoroethane](#) or R-134a refrigerant),

which is approved by the FDA as a propellant due to its inertness. It has zero potential of flammability, is non-toxic, and does not leave residual contaminants that would affect other surrounding systems in case of leaks or bursts. A key feature of the propellant is that it is a compressed fluid, which differs from a cryogenic fluid in that its molecular weight is relatively high (i.e. 102 g/mol) which translates to a high boiling point of 247 K. Operationally, this means the fluid is self-pressurizing at the design RAMPART satellite temperature range, effectively eliminating pumps in the system by using temperature to control the pressure.

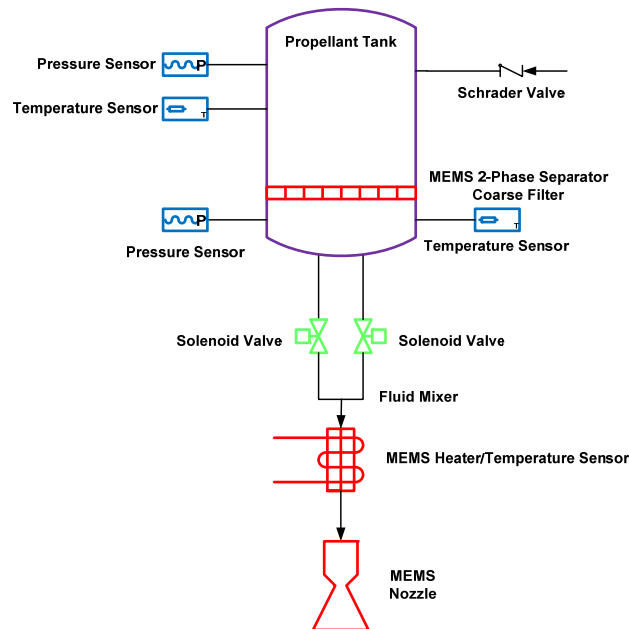

Figure 4. Schematic of the RAMPART Propulsion System

The schematic above shows a tank containing the propellant that is separated from its downstream components by a MEMS membrane of porous channels (50-100 μm diameter, 500 μm deep) etched by Deep Reactive Ion Etching (DRIE). This membrane acts as a phase separator that prevents the liquid phase of the fluid from being injected into the thruster system downstream. Its operating principle is to utilize surface tension at the walls of the channel to prevent the liquid phase from passing through without affecting the gaseous phase pass-through. Even if the material region of the propellant contacts or envelops the membrane, only the gas phase will pass through. Separately, it acts as a coarse filter in

the propulsion system even though the propellant will be pre-filtered during the filling procedure through an integrated Schrader valve. The gas-phase propellant is controlled by the 2-way solenoid valve assembly downstream. In order to create an RPS that generates 0.5 N of thrust in vacuum, three LEE™ EP (Extended Performance) valves are being used. The valves are temperature rated to 135 C or 800 psi, which is well above the design point of the expected conditions (30C, 120psia). The valves are rated at 12V, 0.5W, and 500Hz. Throttling of the RPS is achieved by using the Pulse Width Monitoring (PWM) technique.

RAMPART Thruster Design

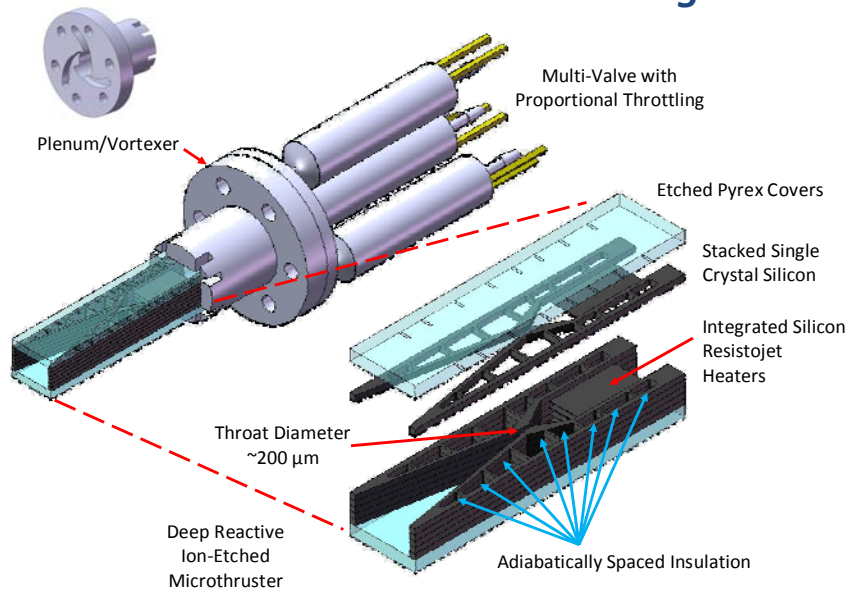

Figure 5. Enlarged View of RAMPART Thruster

Downstream of the valves and a swirl flow mixer is the heater section, which is integral with the 2-D nozzle. The heater/nozzle assembly, shown below, consists of layers of bonded silicon and is micro

fabricated using MEMS technology. The nozzle expansion ratio is 50:1. The nozzle walls are designed as an adiabatic surface to minimize heat loss (hence efficiency) that is typical of resistojets.

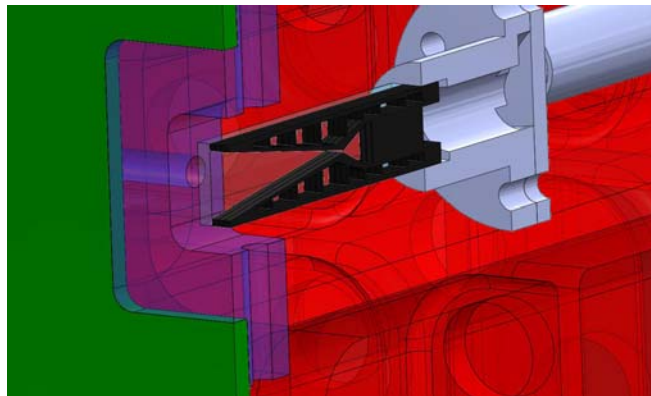

Figure 6. MEMS Heater/Nozzle Assembly

Although the operation of the propulsion system is inherently fail-safe, COTS MEMS pressure sensors, integrated MEMS heater/temperature sensors, and resistive temperature detectors (RTD) are being used to instrument the RPS. The temperature and pressure in the propellant tank on both sides of the MEMS membrane are monitored to provide mass flow rate

calculations and provide against the possibility of reaching rated conditions. The MEMS heater is a resistive element and will be switched between heating and sensing RTDs to check and feed-back control the heater.

The baseline propulsion system concept has been demonstrated on a terrestrial prototype by the Aerospace Corporation, where Dr. Huang worked previously as a member of a small nano/micro-technology team (sans the resistive heating. The high

speed nature of the valve will allow the RPS to operate in phase with the satellite oscillation and CG shifts during thrusting. This latter issue is also mitigated by short “burns” (10 sec) during each cycle of thruster operation.

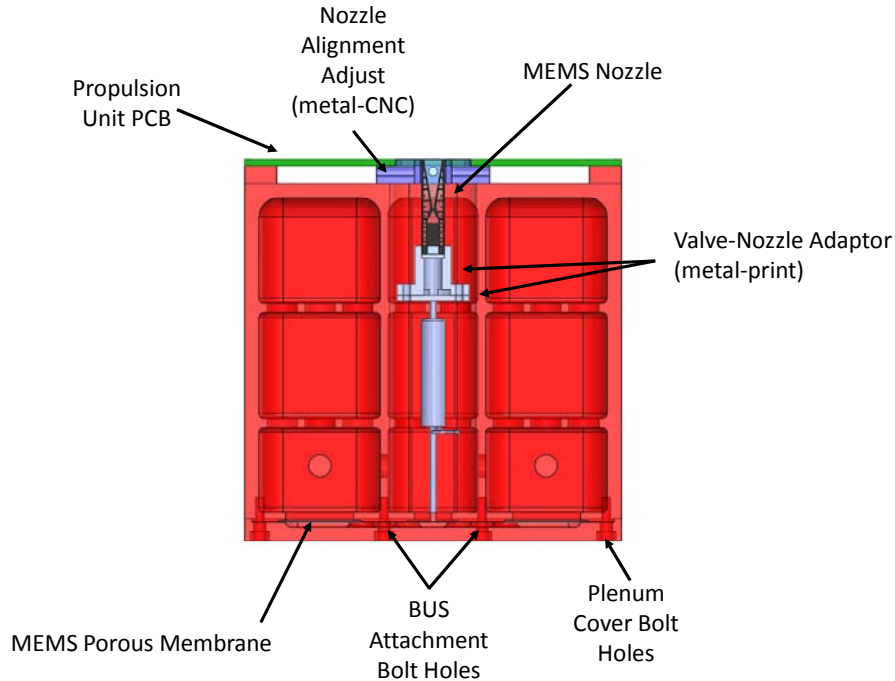

Figure 7. Cutaway Top View of Propellant Tank Showing Buried Valves, Heater and Nozzle

ENVIRONMENTAL TESTING

RAMPART will be subjected to vibration and thermal/vacuum testing in facilities at the Space Dynamics Laboratory in Logan, UT during the Fall of 2010, in preparation for shipment in early 2011 to

Kirtland AFB for pre-flight functional testing, followed by insertion into its PPOD and final vibration of the assembled payload.



Figure 8. Environmental Testing Facilities at SDL
CONCEPT OF OPERATIONS

Following launch and deployment from its PPOD, RAMPART's batteries will begin to charge and will activate a timer to bring the satellite's electrical systems on line. The 8 bit 10 MIPS CPU in the DH/EPS board will first command an electric motor to rotate the hinged solar arrays forward into their 135 deg operational attitude. It will then send a command to heat a wire that will sever the nylon leader material that has been restraining the self-erecting measuring-tape UHF/VHF/S-band quarter-wave dipole antennas, and they will spring into position. The U.S. Space Command will acquire RAMPART with its Space Surveillance Network SSN radars and will publish its first orbital Two-Line Element (TLE) set. The command center at Morehead State University will send UHF commands to RAMPART to start performing its health status monitoring checks and transmitting the results via VHF at 9600 baud to a world-wide network of amateur radio ground stations, as well as via S-band at 38.4 kbaud to the 21-meter-dish-equipped station at Morehead State and stations in the Universal Space Network (USN). Dr. Ben Malphrus of Morehead State and Jay Heberle of USN are planning to install a UHF/VHF station at USN's Hawaii facility. The much broader beam width of the VHF Yagi antenna

will assist the large dish with its very narrow antenna pattern to locate the satellite's S-band transmission.

When the propulsion control team members - Adam Huang at the U. of Arkansas, Jim White at Colorado Satellite Services, Bob Twiggs and Nate Fite at Morehead State, Wes Bradley at Analytical Graphics and 2Lt. Thomas Chiasson at MIT - have become satisfied that the satellite is healthy and in a well-documented orbit, they will begin to transmit stored commands to the satellite to release ten-second pulses of propellant each time the satellite passes over the earth's magnetic equator on its ascending node and aligns its longitudinal axis parallel to the surface of the earth..

Following each release of propellant, the team will assess the new orbital path, as provided by the SSN, and will upload another set of stored commands. Through iterative orbital measurements and modifications to the "burn" timing commands over the next few weeks, they will raise the apogee of the satellite's orbit to 1200 km, while leaving its perigee at 450 km and its inclination close to 45 deg. The radiation test phase of the mission will then begin.



Figure 9. S-Band and UHF/VHF Antennas in RAMPART Ground Station Network

ORBITAL RADIATION TEST PHASE

Once the satellite is in its proper 450km by 1200km elliptical orbit, the performance of its Cubeflow and solar cell experiments will be sampled and stored at regular intervals and downloaded, together with energetic particle flux data from the DAVE

experiment and routine housekeeping data, to the aforementioned UHF/VHF and S-band ground station networks. The Morehead State control station will archive the data and distribute them to all interested parties. The predicted lifetime of RAMPART, after

placement in its final orbit, has been calculated to be approximately ten years (depending on solar activity) by Wes Bradley of Analytical Graphics, Inc. and 2Lt Thomas Chiasson, a recent graduate of the U.S. Air Force Academy Department of Astronautics.

Bradley has prepared a separate paper on his STK-based methodology for determining when and where to make the “burns” during the propulsive phase of

the RAMPART mission, as well as his predictions of energetic particle radiation that will be encountered during the radiation test phase of the mission². The paper is scheduled for delivery at the 2010 Cubesat Developers’ Summer Workshop on the weekend immediately preceding the 2010 Small Satellite Conference.

SUMMARY AND CONCLUSIONS

A diverse team of volunteers is attempting to improve the utility of Cubesats by flight demonstrating a safe and inexpensive propulsion system that can be used with simple passive magnetic stabilization to alter their orbital altitudes, following deployment into less than desirable initial orbits. The

team is also certifying rapid prototyping as a convenient and low-cost means of designing and building satellites, by adapting laser sintering and metal plating processes and materials from the Formula 1 racing field.

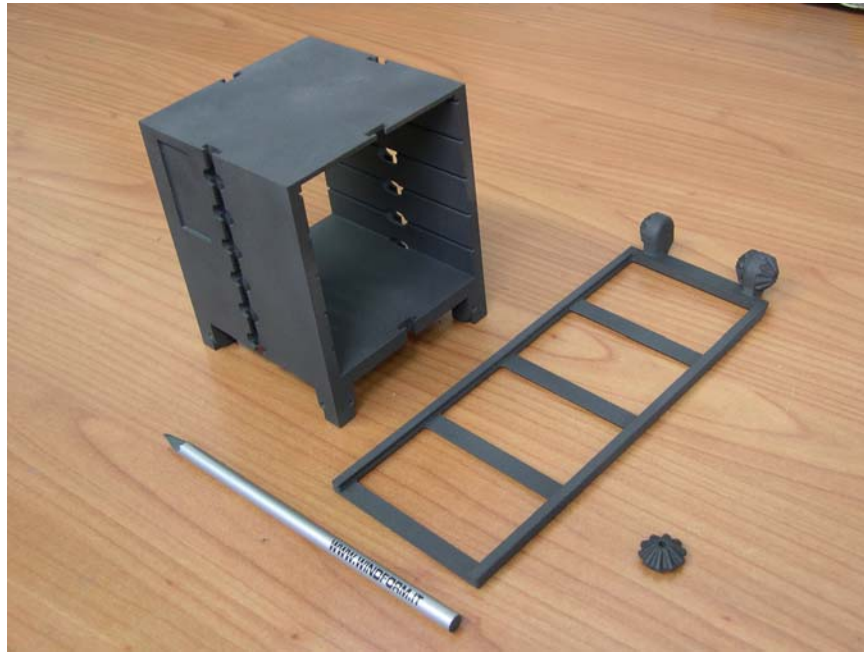

Figure 10. Laser-Printed WINDFORM RAMPART Card Cage and Solar Cell Support Panel

Finally, these volunteers are helping the Air Force Research Laboratory Space Vehicles Directorate perform long-term testing of radiation-hardened

components and improved solar cells and cover glasses in a region near the Inner Van Allen Belt.

REFERENCES

1. White, J., “CSS Bus for RAMPART: The Evolution of PCBSat for the RAMPART Cubesat,” 2010 Spring Cubesat Developers’ Workshop, San Luis Obispo, CA, May 2010.

2. Bradley, W. , “An STK Analysis of Certain Aspects of the RAMPART Cubesat,” 2010 Cubesat Developers’ Summer Workshop, Logan, UT August 2010.

